

GLASS CITY FILM FESTIVAL 2016

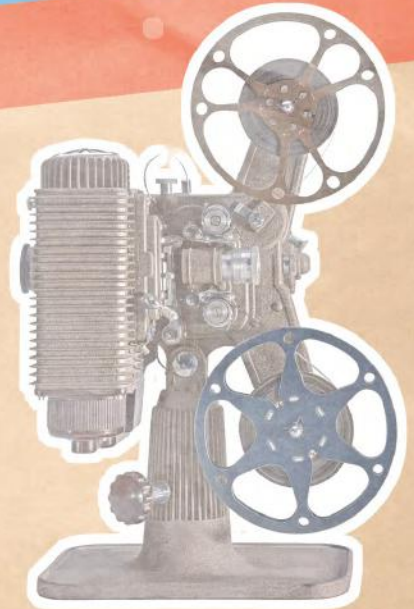

May 19 - 21

Presented by

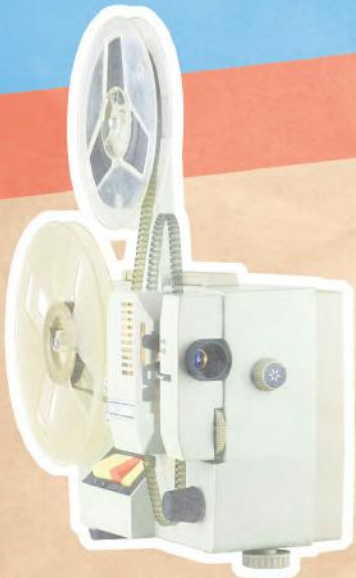
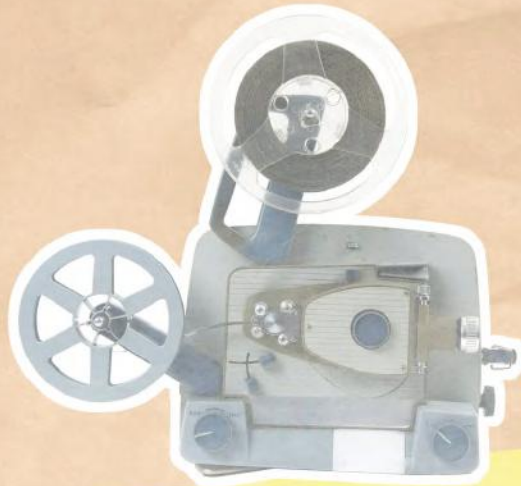

Toledo is jam-packed with unique adventures.
Come see what's trending in Toledo!



Toledo Zoo and Aquarium



Hensville



Glass Pavilion



Hollywood Casino Toledo



Tony Packo's

VisitToledo.org | 800.243.4667

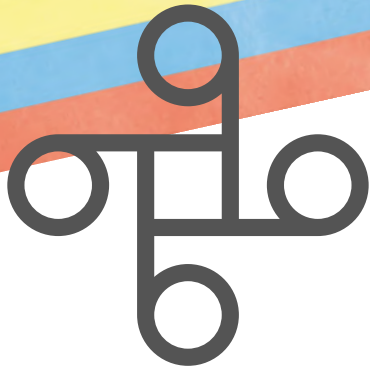

GLASS CITY FILM FESTIVAL

WELCOME TO THE INAUGURAL GLASS CITY FILM FESTIVAL!

Our goal is to offer outstanding films created by some of the most talented filmmakers in the region and beyond.

This year's line up consists of 30 independently made films, representing 11 U.S. cities, 8 countries, and various genres including narrative, documentary, animation, and music video. We're excited to offer a full weekend of short and feature length films, speakers, performances, and more fun opportunities at the Ohio Theatre and Event Center.

As a first year film festival, GCFF aims to celebrate the art of storytelling and empower artists to use technology to share stories in meaningful and unexpected ways. Join us in supporting the arts by enjoying the ultimate movie going experience.

We're thrilled to share these films with you. Thanks for coming to the first Glass City Film Festival! Enjoy the show!

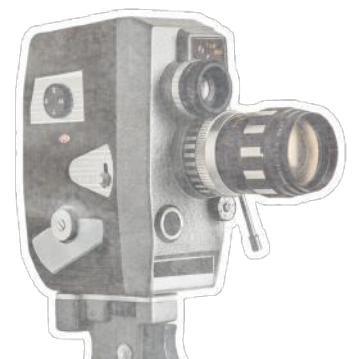



Unlim
 NOTHING IS GIVEN.
 EVERYTHING IS EARNED
 The power of
 TOGETHER WE CAN

THINK.
LIVE.
BREATHE.
CREATIVE.

 **COMMUNICĀ**[®]

INTEGRATED
 MARKETING
 COMMUNICATIONS

Charlotte
 Columbus
 Detroit
 Lexington
 Shanghai
 Toledo (HQ)

800.800.7890 | communicaworld.com

FEST MERCH

TICKETS

Tickets are available at glasscityfilmfestival.com
\$10 per screening block / panel
\$30 Day Pass (Friday or Saturday)
\$60 [Fancy Pass](#)

FANCY PASS

With an all event [Fancy Pass](#) you can experience the entire film festival alongside our filmmakers. Come and go as you please to all film screenings, panels, and enjoy free food at our official after party, Filmmaker Faction. There's plenty to do at the Glass City Film Festival and the [Fancy Pass](#) will help you make the most out of your time at the Ohio Theatre.

T-SHIRT



Corner of US12 & M52 Clinton, MI
800-449-JEEP (5337)

John Akens - President

www.oharachrysler.com

THANK YOU TO ALL OF OUR SPONSORS

PRESENTING SPONSORS



EXECUTIVE PRODUCERS

THE BLADE



Glenwood Boatman

DIRECTORS



LEADING ROLES AND SUPPORTING ROLES



**Rosemary
& Rey Boezi**



PARTNERS

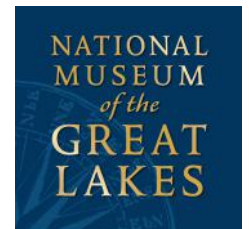
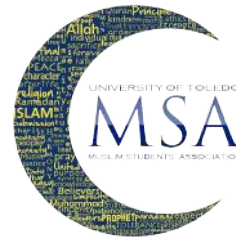

*MultiFaith Council
of NW Ohio*

This film festival and similar Ohio Theatre events are planned in partnership with United North, The Arts Commission, and LISC as part of a city-wide effort to stabilize downtown neighborhoods through the Toledo Strategic Plan for Arts and Culture.

VOLUNTEER FOR THE FEST

The Glass City Film Festival team is incredibly thankful for every person that dedicated their time and sweat to beautify the historic Ohio Theatre & Events Center, the Old Library, and the neighborhood in your spare time. Without our generous volunteers we would not be able to put on such incredible programming for the city we love so much. Every minute donated to this festival is priceless, and has created a living, breathing, cultural experience that is sure to knock people's socks off.

We hold our volunteers in the highest esteem.

If you would like to be part of our team, please be sure to stop a team member and say hello, or send us an email at GlassCityFilmFestival@gmail.com. And please, thank a volunteer! Have a great fest!

The GCFF Team



"POWERFUL... INTELLIGENT... MOVING.
I WANT EVERYONE IN THE COUNTRY TO WATCH THIS FILM!"

MICHAEL MOORE
ACADEMY AWARD®-WINNING DIRECTOR

"A GREAT DOCUMENTARY
AND A GREAT STORY"

HILLARY CLINTON
U.S. SECRETARY OF STATE

"FIRST-RATE"
VARIETY



FORDSON

FAITH FASTING FOOTBALL

NORTH SHORE FILMS ASSOCIATION QURAIISHI PRODUCTIONS A RASHID GHAZI FILM "FORDSON" FOUAD ZABAN BILAL ABU-OMARAH ALI BAIDOUN HASSAN HOUSSAIKY BAQUER SAYED IMAD FADLALLAH
WRITTEN BY RUTH LEITMAN EDITED BY ED PICKART DIRECTOR OF PHOTOGRAPHY MIKE SHAMUS EXECUTIVE PRODUCERS ASH-HAR QURAIISHI & BASMA BABAR-QURAIISHI PRODUCED BY AZAM TAI
ORIGINAL MUSIC BY JOEL GOODMAN ADAPTATION BY RASHID GHAZI

FILM IS NOT RATED BY MPAA

PARENTAL GUIDANCE SUGGESTED FOR CHILDREN. CONTAINS IMAGES AND DISCUSSION OF 9/11 ATTACKS. INCLUDES SOME PROFANITY DURING FOOTBALL GAME.



WWW.FORDSONTHEMOVIE.COM

OPENING NIGHT

THURSDAY, MAY 19

6PM // OHIO THEATRE AND EVENT CENTER

Arrive in style and re-enter a nostalgic movie-going experience! Opening Night is your first opportunity to check out the theater, preview the films and have an opportunity to meet the GCOFF Filmmakers. All filmmakers are invited to speak after every screening block throughout the festival. Audience members can participate in a Q&A and learn about the filmmakers' inspiration and creative process. Glass awards, designed and created by Gathered Glassblowing Studios, will be presented to winning filmmakers. Categories include: Best feature film, Best short film, Best cinematography, Best Editing, Best Produced Screenplay, and an Audience Award.



All Film Screenings are hosted at

**The Ohio Theatre and Event Center
3114 Lagrange Street
Toledo, OH 43608**

Additional programming will be hosted across the street at

**The Old Library
3101 Lagrange Street
Toledo, OH 43608**

FILMMAKER FACTION: AFTER PARTY AT THE ATTIC

**THURSDAY, MAY 19
9PM // THE ATTIC ON ADAMS**

(21+) After Opening Night, please join us at our official after party hosted by The Attic on Adams (1701 Adams St) on Thursday May 19th from 9pm-12am. We're excited to add to the Art Loop energy downtown by coming together and raising a glass to our talented artists. The Attic is famous for it's craft beer selection and delicious food. The evening will also feature live music by Shmotel and Bliss Nova. GFFF Filmmakers, Volunteers, and [Fancy Pass](#) Holders may enjoy free refreshments in the Side Room.

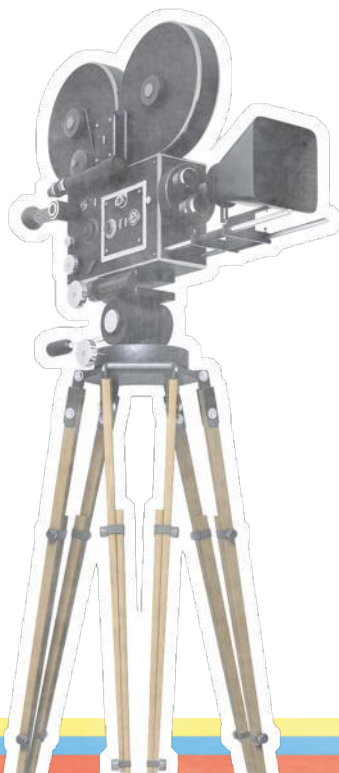

PROGRAM HIGHLIGHT

EMERGING FILMMAKERS

FRIDAY, MAY 20

4PM // OHIO THEATRE

Great filmmaking starts with good exposure. This program highlights rising talent and the next generation of filmmakers. Experience a mix of animation, music video, documentary, and drama.



The Escape

1min. 30sec., Animation

Director: Lilly Rakas

"The Escape" focuses upon a poor little guy trapped inside a whiteboard. Using elements of slapstick comedy, this animation is a lighthearted adventure follows the hero as he succeeds, fails, and then fails again in his attempt to escape the place in which he was created.

The Prison Calls

2014, 3min. 3sec., Animation, Sweden

Director: Henrik Dahlbring

An infamous criminal escapes from prison to seek out something planned way back. The chief police knows exactly where to find him.

The Camera Boy

2015, 3min. 14sec., Comedy

Director: Anthony Wright

As a young man discovers a video camera in his basement, he discovers both joys and shocks of using it.

Bringing Down the House

2014, 4min. 45sec., Music Video

Director: Michael DeSanto

The music video is for the single "Bringing Down the House" from local rapper Stretch. The song is featured on their debut album, "Awkward at its Finest". Shot over a series of five days in various locations throughout the NW Ohio area on a budget of zero dollars. Featuring a cameo from Ryan Wayton, lead singer of Tropic Bombs.

O+AB-

2015, 3min. 30sec., Animation, Iran
 Director: Reza Hadiani

A little blue fish loses his blood and his mother tries to save him, but something is wrong...



Double Sided

2015, 6min. 5sec., Romance
 Director: Jack Campise

Two high schoolers meet and their relationship soon takes off only to quickly end after a few months.



Living Isle

2015, 4min., Documentary, Honduras
 Director: Alex Goetz; Producer: Justin Grubb

In Honduras there exists a chain of islands known as Cayos Cochinos. Recognized as a one of the key sections of the Meso-American Reef to preserve by the Smithsonian Institute, TNC, WWF, and World Bank, commercial fishing has been banned and it has become a marine sanctuary. However, the Garifuna people have lived virtually the same way since the late 1700s, are allowed to remain within the sanctuary, using traditional fishing methods to survive.



Bunee: The Boy from Constanta

2015, 14min. 35sec., Documentary
 Producer/Director: Bunee Tomlinson

After spending the first six years of his life in the dreadful Romanian orphanage system of the 1980's and 1990's, a young boy searches for something to drive him in his new world and discovers that filmmaking could be the engine for his personal growth.



Pursuit

2015, 12min. 41sec., Science Fiction/Thriller/Action
 Director: James Aponte; Producer: Tammy Kinsey

As cities struggle to address overpopulated burrows and side streets, they commission company-contracted bounty hunters known as Collectors, to assist with rampant crime. One such Collector, Briggs, has spent weeks hunting his most elusive bounty yet: a hardened young woman named Valerie. Despite eluding several Collectors, Valerie finds herself desperate as Briggs closes in.



PROGRAM HIGHLIGHT

UNDERSTANDING ISLAM FILM AND PANEL

GCFF is excited to present the Islamic Understanding Film & Panel Discussion. This evening will aim to further understanding of the religion of Islam as well as spotlight the Muslim-American experience in the United States, particularly in the Midwest. Following the film screening in the theatre we'll continue to delve into cultural understanding with a panel discussion in "The Old Library" across the street from the theatre. The evening will also include live musical performances, artists, and food featured mainly in the "The Old Library."

FRIDAY, MAY 20
6PM // OHIO THEATRE



Fordson: Faith, Fasting and Football

2014, 4min. 23sec., Drama

Director/Executrive Producer: Rashid Ghazi

Rashid Ghazi founded North Shore Films to produce *Fordson: Faith, Fasting, Football*—a story which he began developing in 2003 with the basic belief that his fellow Americans were interested in what real-life American Muslims were really like. A lifelong football fan himself, Ghazi felt the story of the Fordson High School football team would make the kind of heart-warming, entertaining film that all Americans could relate to, while giving people a chance to learn more about the values, aspirations and opinions of Arab-American Muslims.

FRIDAY, MAY 20
8PM // THE OLD LIBRARY

Understanding Islam Panel

Engage in a discussion around the Muslim-American experience. Panelists include former Fordson High School Principal Imad Fadlallah (featured in the film), Imam Shamsuddin Waheed from Masji Al Islam, and Dr. Ovamir Anjum the Endowed Chair of Islamic Studies at the Department of Philosophy & Religious Studies at the University of Toledo.

University of Toledo's Muslim Student Association



What is our goal?

- To cater to Muslim's needs on campus
- Provide information on Islam to non-Muslim university population
- Aim to serve our community

Follow us! UToledoMSA



Our MSA office is located in Student Union 3514 AND Jummah Prayer is located in: International House!

Come join us!



welcomeTLC
TOLEDO-LUCAS COUNTY

Welcome Toledo-Lucas County's MISSION is to build a more welcoming and INCLUSIVE community for IMMIGRANTS and people of diverse cultures that SUPPORTS a vibrant civic, economic, and social fabric for ALL.

GET INVOLVED

Contact:

Brittany Ford	Sarah Allan	Yousef Allakbar
419- 213-4539	419- 419-0828	yallakbar@co.lucas.oh.us
bford@co.lucas.oh.us	sallan@lisc.org	

FIND US ONLINE

Welcome Toledo-Lucas County twitter.com/WelcomeTLC



NETWORK OF ARAB-AMERICAN
PROFESSIONALS

MISSION

NAAP-Toledo is dedicated to the development of a prosperous & influential community connected through our national network.

GET INVOLVED TODAY!

- Become a member: NAAPOnline.org
- Toledo@NAAPonline.org
- NAAP-Toledo



LUCAS COUNTY

Greater Toledo Compassionate Community
MultiFaith Council of NW Ohio

PROGRAM HIGHLIGHT

CINEMATHEQUE I

FRIDAY, MAY 20

8PM // OHIO THEATRE

Broaden your depth of field and gain a new perspective. Enjoy back to back independent foreign language films that offer a new perspective on family, love and courage.



Bus Stop

2014, 4min. 38sec., Drama, Korea

Director: Park Soo-Min

Hyun-wook was at the bus stop where he often waited for a bus to a fishing spot with his father when he was young. He met his father there.



Strapped

2014, 5min. 2sec., Drama, Sweden

Director: Henrik Dahlbring

A man and his wife goes through a crisis when the woman admits to wanting to move away from the village they both live in. This upsets the handicapped man and he refuses to listen. And this might lead to the woman leaving her husband behind.



The Knights

2015, 11min. 23sec., Drama, Iran

Director: Hosein Jalilvand; Producer: Amir Mohammad Tajik

An old man finds his way through the narrow uphill alley he must pass to deliver his dry wastes is busy with lots of passing cars...

War and Peace

2015, 5min. 15sec., Music Video, Iran
Director: Mojtaba Yari; Producer: Sylvia Basleh

Jangh o Sol (War & Peace) is a fantasy music video acting in an indefinite country and showing an army officer and his soldiers leaving for war. Whereas suddenly there comes a message that the war is over—now and forever. A dream—that all of us—are living for.



Gotya

2015, 15min. 12sec., Drama/Adventure, India
Director: Devansh Mathur; Producer: Atul Mathur

Based in the quaint hill station of Panchgani, this film follows the story of two teenage boys exploring the world around them on cycles and how their relationship changes due to external factors.



Family Meal

2014, 20min. 40sec., Comedy/Drama, Korea
Director: Park Soo-Min

Kyung-mok cannot understand why his mother always comes back home later than his father as a housewife. One day, he tried to follow her back.



PROGRAM HIGHLIGHT

CINEMATHEQUE II

FRIDAY, MAY 20

10PM // OHIO THEATRE

Broaden your depth of field and gain a new perspective. Enjoy back to back independent foreign language films that offer a new perspective on family, love and courage.



Dolphin Skin City

2014, 19min. 50sec., Drama/Romance, France
Director: Pierre Gaffié; Producer: Marilia Deloison

Eric, an idealistic architect, is on his way to a congress where he must speak about a wonderful project, initiated in Australia: the dolphin skin cities... But at the same moment, he meets a florist, Claire, and falls under her spell. Eric goes from love of architecture to architecture of love...



The Other Night Factory

2014, 15min. 52sec., Drama, France
Directors: Nathalie Giraud, Timothée Corteggiani

Helpless and confused, Andrea goes back to the factory where she used to work. Clinging on her past, she tries to survive. But the violence of reality will shatter all of her illusions.



The Refugee (Muhazir)

2015, 34min., Drama, Afghanistan
Director: Asad Sikandar; Executive Producer: Rajesh Suvarna

Based on True Story Muhazir illustrates the harrowing journey every refugee makes. After leaving Afghanistan for neighboring Iran with his family, Farhad is grateful to be in one place with his wife and children, despite their debilitating poverty. But when a turn of events puts his daughter's future in peril, he must choose between saving himself and the chance to give his loved ones a chance at living a life worth living. A true testament to the power of pride and courage, Muhazir conveys the depths of a father's love, the fragility of family and the everyday battle refugees must fight — for even the most basic of human rights.

TALLSHIP TALES & SHIPWRECK STORIES

**SATURDAY, MAY 21
12PM // OHIO THEATRE**

Join sailors, poets, and shipwreck divers for a storytelling event. Celebrate sailing, exploration, and the past. Enjoy a regionally-produced feature length documentary and then hear from shipwreck hunter, David Trotter in a Q&A session following the film.



Graveyard of the Great Lakes: A Shipwreck Hunter's Quest to Discover the Past

2015, 50min., Documentary
Director: Eric Seals; Producer: Kathy Kieliszewski

Great Lakes historians say up to 10,000 shipwrecks are at the bottom and they are full of history. 74-year-old shipwreck hunter David Trotter has spent half his life hunting for them, exploring and telling their stories. This documentary is about three of the many shipwrecks he has found on Lake Huron. You'll learn about the life and death struggle aboard for the sailors, the heroic connection to the past and the story of a lone survivor.

PROGRAM HIGHLIGHT

RESURGENCE IN THE RUSTBELT

SATURDAY, MAY 21

6PM // OHIO THEATRE

Hear from local artists and community leaders about the supporting role filmmaking and the visual arts play in positively impacting community.



Toledo, My Father

2015, 7min. 53sec., Experimental

Director: Carson Parish

An underexposed night on the town with my father. Inspired by a dream, he drives around Toledo, Ohio remembering his favorite bygone movie theaters. Highlights include the Valentine Theater, the Westwood Theater for the Arts, and the Jerry Lewis Cinemas.

Congratulations to

The Ohio Theatre
for hosting the inaugural
Glass City Film Festival

*And thank you
for screening*

**THE LAST OF
Little SYRIA**

A DOCUMENTARY BY
THE BLADE

THE BLADE



STEVEN BOATMAN
Narrative Filmmaker

Cell #: 419.349.3225
sb@StevenBoatman.com
www.StevenBoatman.com
FB: [fb.com/StevenBoatman](https://www.facebook.com/StevenBoatman)

SHOTS WITH FILMMAKERS*

SATURDAY, MAY 21

8PM // OHIO THEATRE

These short films remind us that life is just a brief intermission between birth and death. This series is perfect if you enjoy white lies, manic rage, and dead bodies... Hey, accidents happen.

**Some content may not be suitable for children.*



The Red Thunder

2015, 6min. 26sec., Drama

Director: Alvaro Ron

Sarah (Allie Grant, "Weeds"), a nerdy teenager, needs her mom's brand new car to go on a date with Danny (Miles Heizer "Parenthood"), the boy she is in love with. Her mom, Dr. Thun (Karen Strassman, "Silicon Valley"), an absent minded Podiatrist is concerned about Sarah driving by the dangerous streets of downtown Los Angeles. She tells her daughter she may need her car if one of her patients has an emergency, but Sarah doesn't buy it. After all Dr. Thun is just a Podiatrist... Sarah receives a message from Danny asking if she is going to pick him up and she decides to disobey her mom and steal the car. Little does she know the vehicle is actually part of a secret Dr. Thun keeps and this discovery will change Sarah's life forever...



Keep It Clean

2015, 11min. 24sec., Dark Drama

Directors: Evan Sennett, Matthew Rivera

A greasy, disgusting salesman dies in a clean freak's home. The clean freak has to figure out what to do with the body.



The Chest

2015, 24min. 20sec., Comedy/Drama

Director: Nathan Elias

Oliver, Riley, and Jeb reunite after many years to assess their late father's will. Oliver is in the middle of a manic depressive attack when Riley calls him in a race to get to their father's house before their swindling brother, Jeb. Riley and Jeb's bickering only escalates Oliver's manic rage.

Heat Wave

2015, 10min., Drama/Thriller
Director: Russ Russo

Kiowa Gordon (*Twilight Saga's* Embry Call, SundanceTV's *The Red Road*) stars in this tale of friends who awaken in a Los Angeles heat wave to find one of their own dead. Anxious with amnesia, they must decide what to do before the heat wave becomes a living hell.

Heat Wave, a modern-day morality play inspired by the 1960's *The Twilight Zone* show, is about consequences of life and death.

Last Night (Dernière Nuit)

2015, 15min., Dark Comedy, France
Director: Emmanuel Roudaut

An evening of drunkenness celebrates the end of a rental. That night, a threesome leads to the accidental death of a woman. Two roommates must make the body vanish before the movers come.

A Way Out

2015, 13min. 45sec., Crime/Drama/Thriller
Director/Producer: Jason Tostevin

For aging gangster Vic, a ride with his upstart protege becomes a twisted game of cat and mouse when both killers discover the other has been keeping a deadly secret.





Kickstarted

**THURSDAY, MAY 19
7PM // OHIO THEATRE**

2015, 1hr. 18min., Documentary

Directors: Jason Cooper and Jay Armitage

Producers: Chris Gartin, J.P. McMahon, Tristan Drew

Synopsis: “Kickstarted” is a documentary film about the crowdfunding revolution. It follows the experiences of three creators – a musician, a filmmaker and an inventor, all of whom use to crowdfunding to pursue their lifelong dreams. Each creator puts their reputation, their financial future and their creative lives on the line in order to convince the crowd their dreams are worth funding. At the center of the film is Brad Carter, a musician suffering from a neurological disease that is slowly eroding his ability to play guitar. Racing to make an album before his skills fade forever, he turns to the crowd for the funding he needs. It’s only after he gets funded that the odds are truly stacked against him.

Biography: Jason Cooper and Jay Armitage are both seasoned content creators and producers with a passion for documentary storytelling.

Prior to working on Kickstarted, Jason was a lead in-house producer with NBC Universal’s Digital Studio where he helped create numerous original digital series. In 2011, Jason started King Toledo Entertainment, a production company focusing on digital, branded entertainment. In the last four years, he’s produced and directed nearly 100 original short form documentary and branded entertainment videos for partners like Intel, Mashable, Capital One, Chase, Stoli, Cadillac and more. Jason is originally from Toledo, Ohio and a graduate of the University of Michigan.

Originally from Harrogate, UK, Jay founded Ralph a BAFTA

winning / Emmy nominated creative production shop with offices in London, New York and Los Angeles. In that role, he worked on major studio films and TV projects including *The Hangover*, *Nightmare on Elm Street*, *Bruno*, *Bridesmaids*, *Breaking Bad*, *Dexter*, *Fringe* and *The Vampire Diaries*.

Jason and Jay met in 2009 and soon bonded over a mutual passion for documentary film. They almost immediately began making plans to co-direct a feature film. Having found a topic that fascinated them both in crowdfunding, they soon started working on what would become “Kickstarted.” Production began in 2013 when they interviewed Amanda Palmer and Zach Braff. A few months later they were running their own Kickstarter campaign and they haven’t looked back.



Lutah, A Passion for Architecture

FRIDAY, MAY 20

12PM // OHIO THEATRE

2014, 1hr. 5min., Documentary

Director: Kum-Kum Bhavnani

Writer: Ryan Pettey

Producer: Gretchen Lieff, Leslie Sweem Bhutani

Archivist: Melinda Gándara

Synopsis: *Lutah* explores the life of a remarkably versatile architect who left an impressive legacy. Initially eclipsed by her male contemporaries in the early 20th century, Lutah Maria Riggs navigated her way through the male-centric world of architecture and brought a freshness to the established architectural styles of Southern California. Riggs blazed a trail for women, relying on the courage of her convictions and a hint of eccentricity. She pursued her passions and created a life of independence, an exceptional choice for a woman at that time. Never before seen photographs and journal entries from Riggs's personal collection, and candid interviews, this documentary reveals a side of Lutah Maria Riggs that has gone unnoticed.

Biography: KUM-KUM BHAVNANI (DIRECTOR / PRODUCER / WRITER) is a university professor by day at UC Santa Barbara, teaching about third world, gender and culture...and a film-maker by night. She has moved continents a number of times during her life, but has been settled in California for the last 20 years. Kum-Kum lives with her two fabulous children, Cerina and Amal, and her just-as-fabulous partner, John.

FEATURED FILMS



Unverified: The Untold Story Behind the UNC Scandal

**FRIDAY, MAY 20
2PM // OHIO THEATRE**

2016, 1hr. 30min., Documentary
Director: Bradley Bethel

Synopsis: After a college writing tutor's colleagues are falsely accused in a university athletics scandal, he becomes determined to set the record straight. Along the way, he realizes he's up against more than he anticipated.

Biography: Bradley Bethel is an unlikely documentary filmmaker. He originally studied writing at The Ohio State University and earned a master's degree in English Education from the University of Toledo. While working as a writing tutor and reading specialist at the University of North Carolina, news broke of a scandal involving UNC's athletics department, and Bradley's colleagues were caught in the middle. Outraged after seeing his colleagues scapegoated, he became determined to set the

record straight and thus began work on UNVERIFIED, his first documentary.



Fools

SATURDAY, MAY 21
2PM // OHIO THEATRE

2015, 1hr. 27min., Romance
 Writer/Director: Benjamin Meyer
 Producer: Beth Schacter

Synopsis: FOOLS is the story of Sam and Susan, who move in together without exchanging a word. He's barely hanging on after being fired, again. She is fleeing an angry roommate. They make it work, the way two strange people can sometimes make strangeness work for them. They fabricate a life for themselves, making up a rich romantic history. But when their story is tested by reality, they must decide whether what they share is truly love, or just a fantasy.

Biography: Benjamin Meyer is a writer, director and editor working in Los Angeles. His short film WHAT ARE YOU HAVING? won the Grand Prix du Court-Metragé at the Deauville Film Festival (Roman Polanski, jury chair), a CINE Golden Eagle, and Best Short Film at the

Abuja International Film Festival in Nigeria. His prior short, GEORGIE PORGIE won "Best Short Film" at the Chicago Underground Film Festival, the Boston Underground Film Festival and the Seattle Underground Film Festival; "Best Director" at the Georgetown Independent Film Festival; "Best Drama" at the IFP/Chicago Film Festival; and a Bronze Plaque at the Columbus International Film Festival. He also won multiple festival awards for his prior two shorts, SOLD and BOTHERED. Benjamin received his BA in Film Studies from Wesleyan university with High Honors, and received his MFA in Film Production from Northwestern University. As an editor he has worked on feature documentaries and television specials with such award-winning

filmmakers as Michele Ohayon, Ondi Timoner, Eddie Schmidt and Peter Stuart. He edited the feature film NORMAL ADOLESCENT BEHAVIOR for New Line Cinema. Meyer's short story (and yourself) was recently published by Mullholland Books as part of their Popcorn Fiction series.



Up This Hill

**SATURDAY, MAY 21
4PM // OHIO THEATRE**

2015, 1hr., Documentary
Director: Paul Sobota

Synopsis: Cleveland area teens take a week long service-learning trip to Harlan, Kentucky to build homes for low-income families. They give their all, laboring under an unforgiving sun, and lifting each other up along the way. They end up getting much more in return.

Biography: Based in Cleveland, Ohio; Paul Sobota has worked with regional non-profits and commercial clients to tell their stories through still photography and filmmaking. Over the past five years, Paul's focus has shifted strongly to cultivating his own voice in documentary filmmaking, leading up to creating his first feature length documentary, *Up This Hill* (2015).

THE OHIO THEATRE PROJECT

GCFF is one of many cultural programs made possible by United North, a community development corporation in Toledo's Old North End. United North's services include housing assistance, business services, village council meetings, financial coaching, and leading the revitalization of the Ohio Theatre and Event Center.

The Ohio Theatre, built in 1921, is a three-story brick and stone masonry building in the heart of the Lagrange Street business district. Over the years, the Ohio Theatre has entertained Toledo residents with shows ranging from vaudeville and silent films, to movies and performing arts. You may have heard about or remember past performances such as the Moscow Boys Choir; the Warsaw Wind Quartet with Michiko Otaki; Jamie Farr and William Christopher in *The Odd Couple*; Mickey Rooney performing with his wife, Jan Chamberlin; or Dale Evans and Roy Rogers visiting with Trigger. The Ohio Theatre has been "the place" for special events for generations, such as in 1960 when John F. Kennedy gave a campaign speech on the Ohio Theatre's stage.

The Ohio Theatre was a neighborhood gathering spot for sharing experiences like family outings, first kisses, and fun with childhood friends. The theatre was part of a vibrant neighborhood that had a variety of thriving businesses. It was a community cornerstone, and it can be again.

Please consider making a donation during this year's festival to support the historic Ohio Theatre.

Visit ohiotheatretoledo.org to learn more.

WHAT IS “THE OLD LIBRARY” ANYWAY?

HISTORY & CHARACTER IN POLISH VILLAGE

Built in 1923 as the Ohio Savings Bank, the building retains many original features such as the mezzanine, art deco architecture, and ceiling tile design. In an effort to expand into Toledo’s Polish neighborhood, the building was later converted into the Central-Lagrange Library in 1934. After 40 years the public library was relocated and “the old library” later housed a couple tenants including a restaurant-pub and a coffee house. The building is now stewarded by United North and has been a meeting place for community volunteer events, such as the annual pączki sale. By opening the doors during the film festival, we hope to bring attention to the under-used space. We believe that arts and culture activities are a catalyst in building a lively business corridor.



Please consider exploring that space in between film screenings. Your presence helps to strengthen community and sense of place.

THANK YOU FOR MAKING GCFF POSSIBLE!

2016 FESTIVAL JURY

Tracy Montri, Toledo Lucas County Public Library
Kirk Baird, Toledo Blade
Michael Butcher, Mid Ohio Filmmakers Association

SPONSORS

Destination Toledo
CommunicA
Toledo.com
Toledo Blade
FJ Westcott
The Attic on Adams
Glenwood Boatman
O'Hara Chrysler
Minuteman Press
Rey and Rosemary Boezi

PARTNERS

Toledo Community Foundation
United North
The Arts Commission
LISC Toledo
FilmFreeway.com
Park Inn by Radisson Hotel
Gathered Glassblowing Studios
Dennis Sawan, Right Half Media

GCFF TEAM

Lindsay Akens
Jamie Brown
Hasan Dudar
Phillip Echelberry
Will Ellis
Thomas Harrison
Daryl Layson
Beth Powder
Katie Rausch
Kim Sanchez
Daniel Woodcock

OHIO THEATRE BOARD

Sarah Allan
Rey Boezi
Ryan Bunch
Charles Herman
Jim Hill
Jennifer Jarrett
Tom Jesionowski
Diane Kornowa
Lorraine Kwiatkowski
Larry Meyer

UNITED NORTH STAFF

Nikki Morey
Steve Seaton

